

The **ED8660 Backpack** features electrostatic cleaning technology combined with ElectroDefense's patented, first to market **SmartSprayer™** and **SprayTrack™ mobile job accountability technology**, puts control into your hands for the most efficient fluid dispersal possible.

The **ED8660's** robust, yet sleek ergonomic design offers unparalleled comfort, lending itself to more effective deployment throughout all tasks.

Convenient anodized aluminium no tool 4-in-1 twist micron size adjustor with fluid return & system clean nozzle

130 lumen focus light

One click electrostatic or regular spray activator

One click self cleaning function

Bright, back lit system diagnostic & operational LCD color display

Wrist Stress Relieving Ergonomically Designed Gun & Holster Clip

High-grade memory foam lumbar, shoulder & waist support

Light weight aluminium clips

Rapid release aluminium gun holster

Non-slip dual surface handle

Fluid proof, secure phone storage

Aerospace grade polymer reinforced base

4 hr. run time, 6,000 mAh fast charge battery

Multifunctional splashguard with automated refill IP68 LED

Quick release dual filtration cleaning tank

Advanced polymer tank with best in class corrosion resistance

SmartSprayer™ Wi-Fi & Bluetooth App for live job tracking & inventory management

Trigger lock for comfort & security

6ft Teflon acid & corrosion resistant hose with galvanized steel connector rings

DIMENSIONS

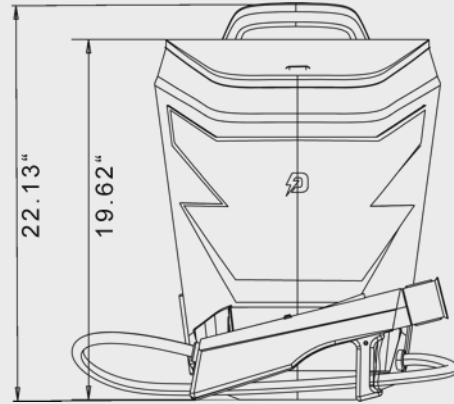
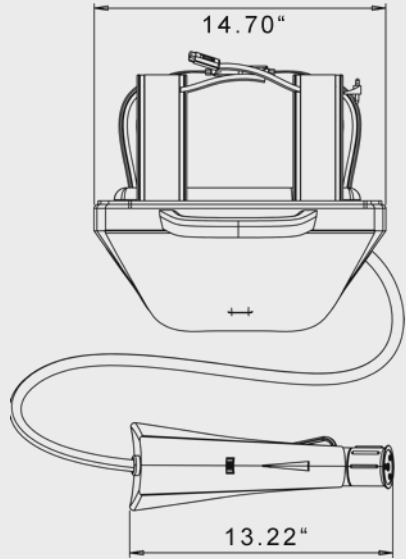

| Warranty | Power |
|-------------------|---------------|
| 2 year extended | 6,000 mAh |
| Weight | Tank Capacity |
| 15lbs (33lbs wet) | 2.25 Gal |

CERTIFICATIONS



THE ELECTROSTATIC EFFECT

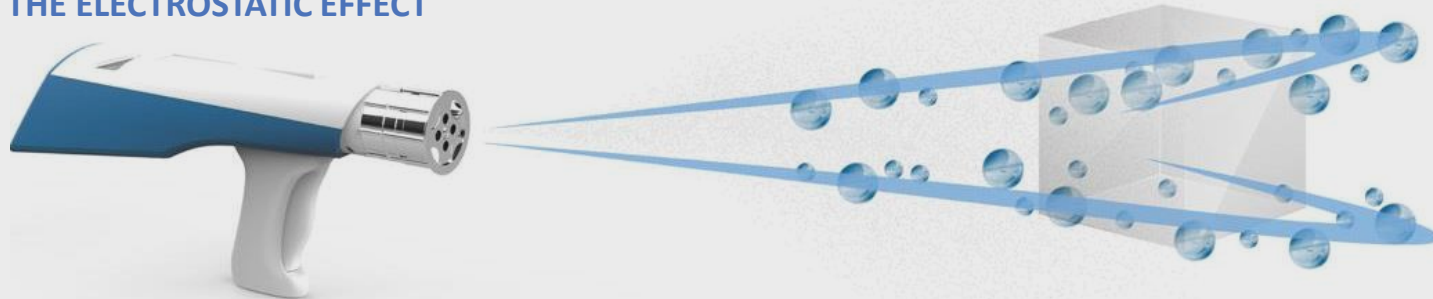

SPECIFICATIONS

| Nozzle Setting | 50 microns | 80 microns | 110 microns |
|-------------------|-------------|--------------|-------------|
| Flow Rate | 4 oz/min | 6.75 oz/min | 9.5 oz/min |
| Run time per tank | 71 minutes | 42.5 minutes | 30 minutes |
| Tanks Per charge | 3.4 tanks | 5.6 tanks | 8 tanks |
| Coverage per tank | 25,000 sqft | 20,000 sqft | 14,000 sqft |

| Key App Functions | | | |
|------------------------|-------------|----------------|-----------------|
| System Diagnostics | Fluid Use | Inventory Mgmt | Warranty Mgmt |
| Real Time Job Tracking | Total Hours | Job Comparison | In App Training |

EXAMPLE INDUSTRY APPLICATIONS

